

Installation & User Guide

MK:440 Environmental Noise Microphone

Revision D



This manual, the software to which it relates, the
program code and drawings are all:
© Copyright Cirrus Research plc 2019

The content of this manual, any illustrations, technical information and descriptions within this document were correct at the time of going to print. Cirrus Research plc reserves the right to make any changes necessary, without notice, in line with the policy of continuing product development and improvement.

No part of this publication may be duplicated, reprinted, stored in a data processing system or transmitted by electronic, mechanical, photographic or other means, or recorded, translated, edited, abridged or expanded without the prior written consent of Cirrus Research plc.

No liability is accepted for any inaccuracies or omissions in this manual, although due care has been taken to ensure that it is complete and accurate as possible.

Accessories supplied by Cirrus Research plc have been designed for use with the instrumentation manufactured by Cirrus Research plc. No responsibility is accepted for damage caused by the use of any other parts or accessories.

In order to take account of a policy of continual development, Cirrus Research plc reserves the right to change any of the information contained in this publication without prior notice.

Produced by Cirrus Research plc, Acoustic House, Bridlington Road, Hunmanby, North Yorkshire, YO14 0PH, United Kingdom.

© Copyright Cirrus Research plc 2018

Reference Number 05/22/MK440/22

Document Printing Date Thursday, 10 January 2019

1. **Revision History**3

2. **Important information**3

3. **Product Description**.....4

4. **Technical information**4

5. **Conditions for use**4

6. **MK:440 Overview**.....5

7. **Installation**7

 7.1 Inspection..... 7

 7.2 Location..... 7

 7.3 Installation and wiring..... 7

 7.4 Earth bonding..... 8

 7.5 Optional Accessories 8

8. **Maintenance & calibration**.....9

Appendix 1. DC Voltage output option10

Appendix 2. The influence of the background noise level on calibration and verification11

Appendix 3. CE Declaration of Conformity.....12

9. **Product Guarantee & Warranty Information**.....13

10. **Cirrus Research Offices**15

1. Revision History

Rev	Date	ECN	Engineer	Change
A	24/08/18	N/A	SK	First Release
B	05/09/18	N/A	SK	Pre-approval changes
C	11/09/18	N/A	SK	Changed Low Operating temperature to -30°C.
D	10/01/19	N/A	SK/JSU	Added Rev D on front page. Removed highlighting. Added drawing number in header. Corrected headings. Updated warranty information. Updated approved environment to add Class II.

2. Important information

The MK:440 is approved for use in the following environments:

- NI Class I/II Division 2 Groups C,D,E,F,G T4
- Class I Zone 2 AEx/Ex ec IIB T4
- Class II Zone 22 AEx/Ex tc IIIB T4
- (-30°C ≤ Ta ≤ +60°C)
- IP54

Each MK:440 unit will have its own output levels. Please refer to the factory calibration setup information for details for your specific instrument.

The MK:440 is supplied with the configuration preset to meet those ordered from the factory.

Calpot R1 is referred to in Section 8 for calibration. This is the only setting that should be altered, if required, by the user during a Reference Calibration.

3. Product Description

The sound monitoring device (MK:440) is suitable for use in class 1 division 2 hazardous locations when installed in accordance with these instructions. The device conforms to: IEC 60079-0 and IEC 60079-15 and is suitable for outdoor installation with a rating of IP54.

The MK:440 is supplied with a ½" NPT connection that conduit may be connected to. Alternatively, the NPT thread may be replaced with the supplied gland for routing cables.

4. Technical information

Parameter	Value			Unit
	Min.	Nominal	Max.	
POWER voltage	12	24	27	VDC
LOOPIN voltage	12	24	27	VDC
Current	20		40	mA
Current loop output*	4	-	20	mA
Current loop impedance	-	-	400	Ω
Captive lid screw tightening torque	3		4	Nm
Terminal block tightening torque (J7 & J8)	0.5		0.6	Nm
Weight		2.6		kg
Dimensions(L,W,H)		75,125,480		mm
Operating Temperature	-30		135	°C

**The current output is proportional to the A-weighted noise level, at low noise levels the output can be below 4mA.*

5. Conditions for use

WARNING – DO NOT CONNECT OR DISCONNECT WHEN ENERGIZED

Never replace components unless power is disconnected, or the area is free of ignitable concentrations.

A portion of the enclosure is non-conducting and, under certain extreme conditions, may generate an ignition-capable level of electrostatic charges. The user shall ensure that the equipment is not installed in a location where it may be subjected to external conditions (such as high-pressure steam) which might cause a build-up of electrostatic charges on non-conducting surfaces. Additionally, cleaning of the equipment should be done only with a damp cloth.

The user shall ensure that the equipment is not installed in a location where it is continuously exposed to ultraviolet light.

6. MK:440 Overview

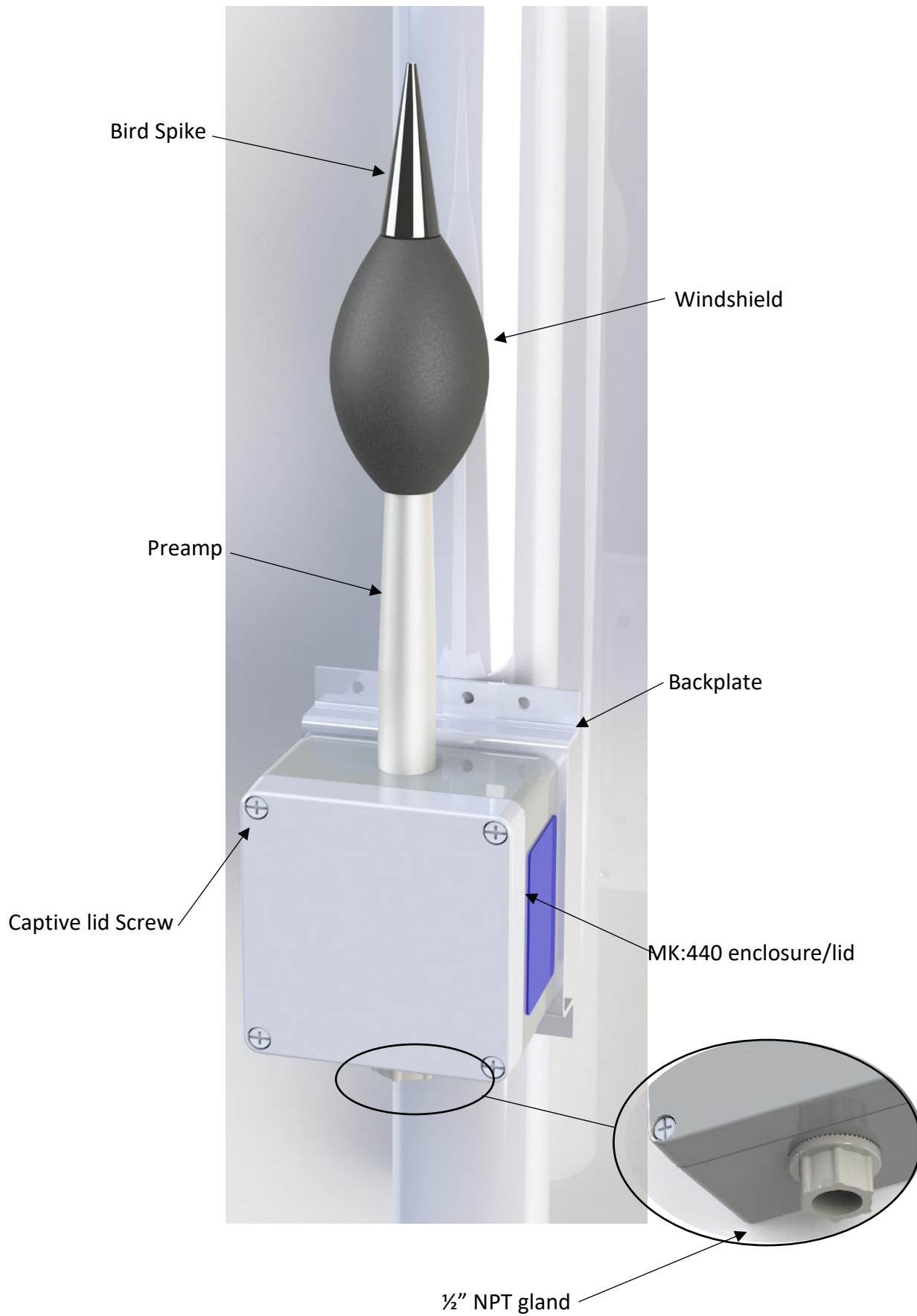

The standard version of the MK:440 has a 4-20mA current loop which outputs a current level, expressed in milliamperes that is proportional to the sound level with either a 'Fast' or 'Slow' Time Weighting. The choice of time weighting is a factory set option made at the time of purchase.

To calibrate the MK:440 an acoustic calibrator must be used. The connected system should then adjust the interpreted level to 93.7dB, see the example below for how to do this.

The output is always weighted with the 'A' frequency weighting which is the most commonly used frequency weighting for the measurement of environmental and industrial noise levels.

The 4-20mA current loop output is ideal for integration to many process measurement and control systems where your own system loggers and software can provide an accurate representation of the 'live' noise levels and also store data.

Your own interface system will need programming with a simple formula which is outlined on your Factory Configuration Information sheet.

For Example:

For a unit with a range of 34 to 104 dB

Sound Pressure Level

$$\text{dB} = (10 \times I) + 20$$

(Where "I" is the output current in mA)

Therefore, in this example an output current of 7.4mA would represent a noise level, L_A , of 94.0dB(A) as shown below:

$$\text{dB(A)} = (10 \times 7.4) + 20$$

$$\text{dB(A)} = 74 + 20$$

$$\text{dB(A)} = 94$$

Please check with our technical department if you need confirmation about the settings of your equipment or if you need any other technical guidance.

Tel: + 44 1733 667100
email: sales@cirrus-environmental.com

7. Installation

Once you have received shipment of your new MK:440 Noise Sensor unit, follow the next stages to setup and install the equipment.

7.1 Inspection

Visually inspect the components of the MK:440 and ensure everything is in order. In the unlikely event that there is a problem with the unit contact your distributor in the first instance.

7.2 Location

Every site and application are different but here are some basic guidelines for effective positioning of your Noise Sensor:

- It is usually worth conducting a noise survey or referring to measurement data from a recent noise survey to understand the noise profiles for the area.
- Install the sensor at a location nearby to where the environmental noise is most likely to have an impact.
- Legislation often specifies where measurements should be made, for example at property boundaries or at a complainant's property.
- Try to mount the unit away from obstacles and building walls.
- The microphone should always be a minimum of 1.2 – 1.5m above the ground level.
- Avoid, where possible, overexposed areas where high wind speeds will affect the noise level readings.

7.3 Installation and wiring

The MK:440 must be wired in accordance with the National Electric code (NFPA 70) or the Canadian Electric Code (CSA C22.1). An installation drawing below shows the electrical connections to be made to the device, note that the power and loop signals can come from a combination of non-hazardous and hazardous locations as long as it is suitably rated.

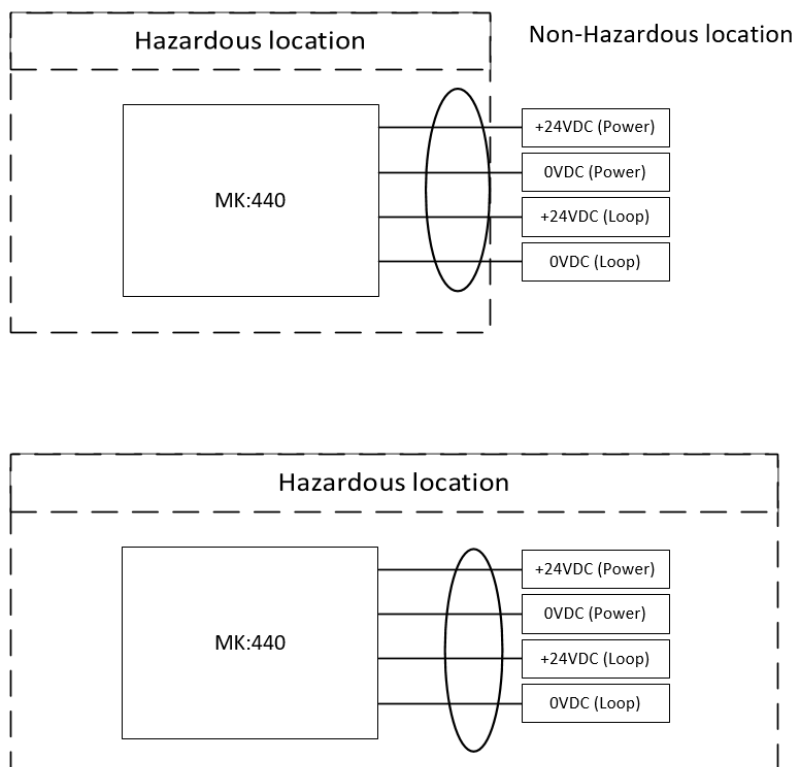

Wherever possible the MK:440 should be wired outside of any potentially explosive atmosphere. A single conductor must be used in each port. The cross-sectional area of the conductor must be between 0.2mm^2 and 0.6mm^2 . The cable must have a temperature rating of at least 80°C and ideally be UL rated. The power and current loop supply must be connected as follows:

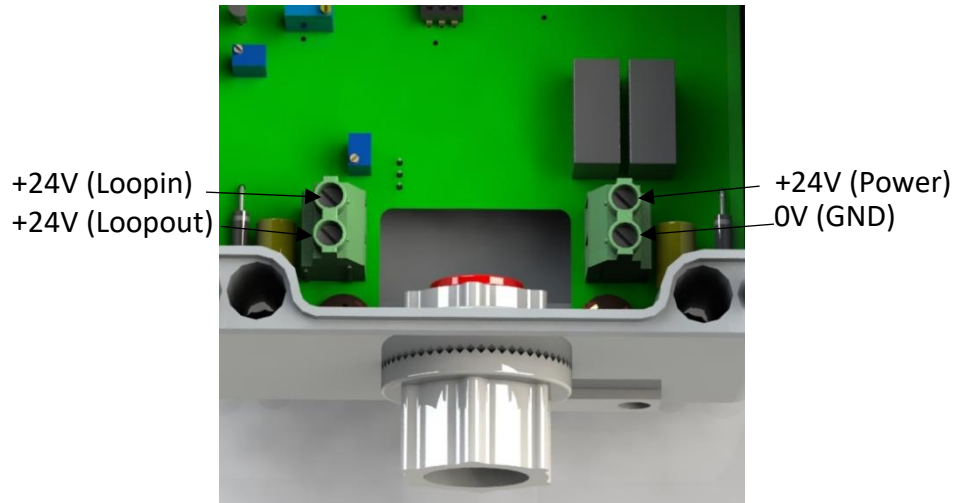

There must be no conductor extending beyond the terminal block, strip wires no more than 10mm.

It is advised to perform a calibration before placing the lid on the enclosure (see section 8), adjusting the calibration potentiometer as necessary. If wall mounting kit BP:440 is being used it should also be attached to the MK:440 before placing the lid on the enclosure.

7.4 Earth bonding

The MK:440 has several earth bonding points, it is essential the product is connected to a suitable ground connection. Earthing points are illustrated below:

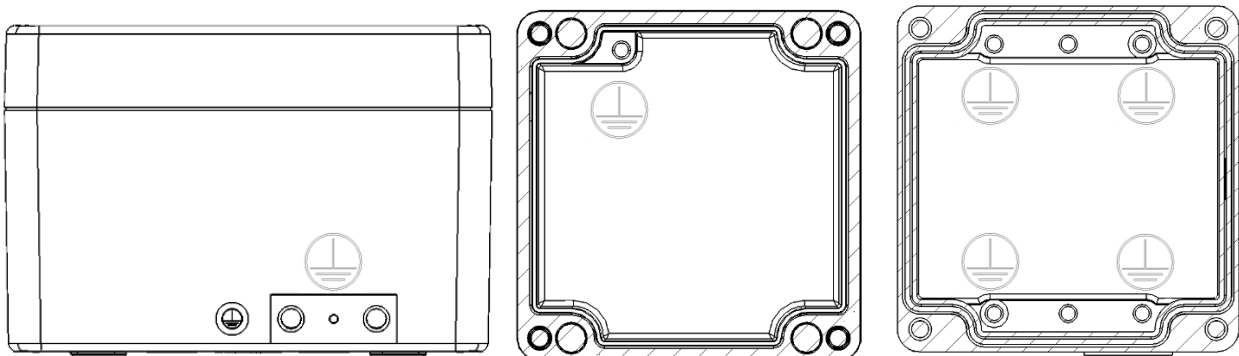

Note that the external and internal earths of the enclosure share an electrical connection, but the lid does not. Both parts of the enclosure must be connected to a suitable ground connection.

7.5 Optional Accessories

The following accessories may be ordered separately from your distributor as required.

Windshield:	UA:440
Wall mounting Kit:	BP:440

8. Maintenance & calibration

The system is designed to be durable and should not need routine maintenance other than calibration. Under no circumstances should the preamp be removed from the enclosure and never remove the microphone from the preamp.

It is recommended that the system is calibrated once a year to maintain the accuracy of the system, it requires removal of the lid of the MK:440 and must be carried out by a competent person in a suitable environment.

A CR:514/CR:515 can be used to set an absolute reference point for the system. The calibrator emits a 94dB tone, the current output then needs to be measured to determine the level being measured by the device. Turning the screw on the blue resistor marked "CAL" will adjust the current output. You will need to refer to your configuration to determine the correct current level for the calibrator output (typically 94dB, see section 5 for an example on current levels).

If turning the "CAL" screw does not allow you to reach the required current level then it is likely that there is a problem with the device and should contact your distributor.

Appendix 1. DC Voltage output option

To convert the 4-20mA output current to a DC voltage output, connect LOOPOUT to the Loop Power Input Ground via a 100ohm resistor for a voltage across the resistor of 10mV/dB.

Appendix 2. The influence of the background noise level on calibration and verification

High background noise levels can affect the calibration of any noise measurement system.

It is recommended that both the routine verification and reference calibration are carried out in environments where the ambient noise level is more than 15dB below that of the calibration level.

The electrostatic actuation system will typically produce a level between 85dB and 95dB. To ensure that the routine verification and reference calibration can be carried out successfully, it is recommended that these are done in environments where the ambient noise level is less than **70dB(A)**

As an example, if the electrostatic actuation system is generating a level of 90dB and the ambient level is 85dB, the resulting level will be 91.1dB. It is also likely that the background noise level will vary and so this will result in an unstable output level.

If the electrostatic actuation system is generating a level of 85dB and the background noise level is 75dB, the resulting level will be 85.4dB.

If the electrostatic actuation system is generating a level of 85dB and the background noise level is 70dB, the resulting level will be 85.1dB.

The chart below shows difference between two noise levels across the x axis and on the y axis the level that should be added to the higher value. This shows the effect of the background noise upon the calibration level. As the difference reaches 15dB, the effect becomes insignificant.

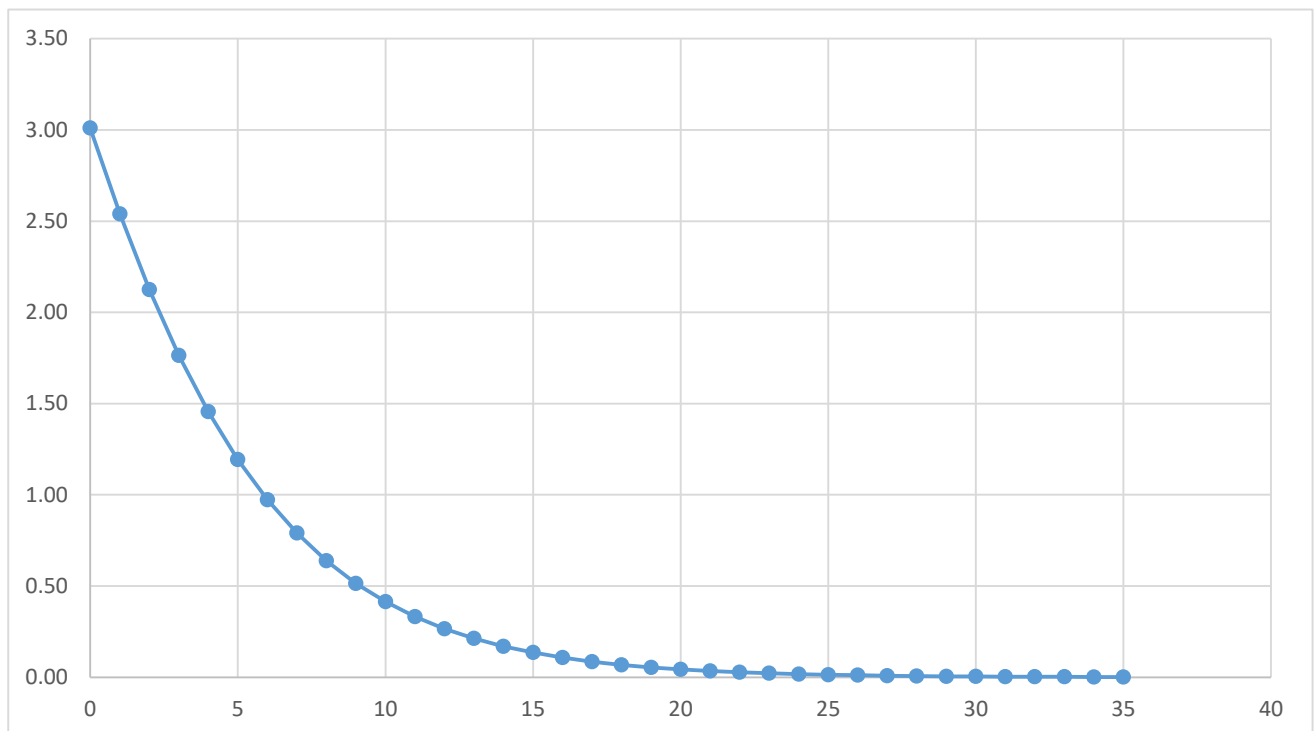

Appendix 3. CE Declaration of Conformity

**Cirrus Research plc Hunmanby UK
CE Certificate of Conformity**



Manufacturer: Cirrus Research plc
Acoustic House, Bridlington Road
Hunmanby, North Yorkshire, YO14 0PH
United Kingdom
Telephone +44 1723 891655

Equipment Description

The following equipment manufactured after 30th May 2018
MK:440 Environmental Noise Microphone

Along with standard accessories
According to EMC Directive 2014/30/EU
meet the following standards

EN 61000-6-3 (2007)

Electromagnetic compatibility (EMC). Generic standards. Emission standard for residential, commercial and light-industrial environments

EN 61000-6-1 (2007)

Electromagnetic compatibility (EMC). Generic standards. Immunity for residential, commercial and light-industrial environments

Signed

Dated 30th May 2018

A handwritten signature in black ink, appearing to be 'M. Williams', written over a horizontal line.

M. Williams
Director

9. Product Guarantee & Warranty Information.

1. The period of the initial guarantee starts from the date of purchase, as a new instrument, from Cirrus Research plc or their formally approved distributors. The periods are as follows unless otherwise stated by Cirrus Research plc in writing:

Products manufactured by Cirrus Research plc	24 months
Repairs	3 months
Replacement microphone capsules	12 months
Spare parts (excluding replacement microphone capsules)	3 months
Products manufactured by a third party (see clauses 12 & 14 below)	Based on the individual manufacturer's warranty

2. The initial guarantee covers all faults and accidental damage to the product.

3. Warranty extension

If the product is returned to Cirrus Research plc or one of its Authorised Service & Calibration Centres for routine verification & calibration after the initial guarantee period, upon completion of the verification the product will be given an additional free one (1) year warranty.

This must be done with a 6-week window of the anniversary date of shipment. This is limited to 3 weeks either side of the anniversary date of the shipment.

It follows that if an instrument is routinely verified by Cirrus Research plc (or an Authorised Service & Calibration Centre) every year after the initial warranty period, the warranty is effectively continuous to a maximum of fifteen (15) years from the original date of purchase.

There will be a charge for the verification (or calibration) of the equipment.

4. Buying back into the warranty

Where the warranty has expired, the customer can buy back into the warranty scheme. This reactivates the warranty for a further 12 months and provides the same level of cover as for the initial period above.

This must be purchased at the same time as a calibration or verification.

The maximum period of any warranty, whether it had been extended or not, is 15 years from the original purchase date.

This offer can only be redeemed once during the life of the instrument.

5. The initial guarantee, and any extended warranty is not transferrable and is provided to the original customer only.
6. Where a product is returned for routine verification or calibration, the customer is responsible for all transportation, duty and other charges.
7. The user shall be responsible for determining if the product is suitable for the use and that such use complies with any applicable laws, regulations or standards.
8. The customer must notify Cirrus Research plc in writing of any claimed defect in the product immediately upon discovering it.

9. Where an instrument is being returned under the guarantee or warranty, it must be returned to Cirrus Research plc without undue delay at the customer's risk with transportation charges prepaid.
10. Where the product is deemed to be faulty due to manufacturing defects, Cirrus Research plc shall:
 - a. Repair or replace the defective products
 - b. Be given reasonable time by the customer to make such repairs or replacements
 - c. Return the product to the customer at Cirrus Research plc's expense
11. Cirrus Research plc reserves the right to decline an instrument under the initial guarantee or extended warranty where;
 - a. The product has continued to be used after defect has been discovered
 - b. There is clear evidence of damage or misuse that is deemed to be more than minor accidental damage
 - c. The product has been modified or repaired by persons other than those authorised by Cirrus Research plc
 - d. The defect arises from the use of the product in conjunction with products or materials not reasonably contemplated by Cirrus Research plc
 - e. No fault is found with the product
12. The initial guarantee or extended warranty does not extend to products or materials not supplied by or manufactured by Cirrus Research plc. Consumable items, including dry-cell and alkaline batteries are not covered by the initial guarantee or extended warranty.
13. Where re-chargeable batteries are used as an integral part of the product design and the product is shipped with the batteries installed (for example the doseBadge5 Noise Dosimeter), the standard product guarantee and extended warranty applies provided that the user has used the correct charging instructions and has followed the charging regime stated in the product manual.
14. No warranty is offered for used equipment unless a special arrangement is made and is confirmed in writing by Cirrus Research plc
15. Cirrus Research plc reserves the right to amend or update these terms and conditions without notice.

This warranty does not in any way reduce or affect the legal rights of the buyer and is in addition to any statutory rights.

10. Cirrus Research Offices

The addresses given below are the Cirrus Research plc offices. Cirrus Research plc also have approved distributors and agents in many countries worldwide. For details of your local representative, please contact Cirrus Research plc at the address below. Contact details for Cirrus Research authorised distributors and agents are also available from the Internet Web site at the address shown below.

Main Office

Cirrus Research plc
Acoustic House
Bridlington Road
Hunmanby
North Yorkshire
YO14 0PH
United Kingdom

Telephone: +44 (0)1723 891655
Fax: +44 (0)1723 891742
E-mail: sales@cirrusresearch.co.uk
Web Site: www.cirrusresearch.co.uk

Cirrus Environmental

Unit 2 Bridlington Road Industrial Estate
Hunmanby
North Yorkshire
YO14 0PH
United Kingdom

Tel: +44 (0) 1723 891722

Email: sales@cirrus-environmental.com
Web: www.cirrus-environmental.com

Germany

Cirrus Research plc Deutschland
Arabella Center
Lyoner Strasse 44 - 48
D-60528 Frankfurt
Germany

Tel: +49 (0)69 95932047
Fax +49 (0)69 95932049
Email: vertrieb@cirrusresearch.de
Web: www.cirrusresearch.de